

# AUTON MOTORIZED PLASMA/LCD SMART SERIES

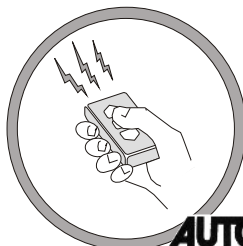
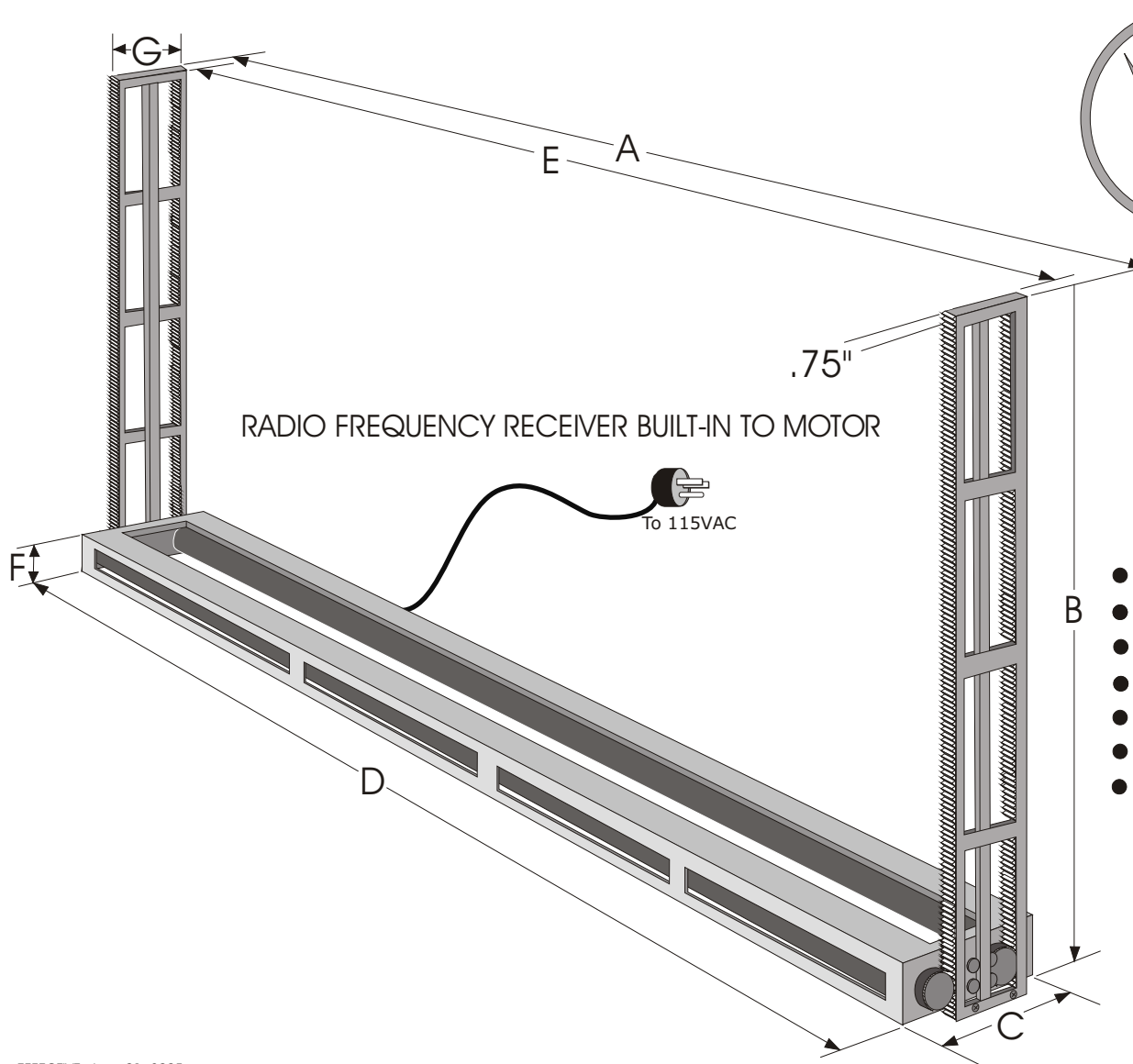

**AUTON POP UP TV LIFTS**

AUTON MOTORIZED SYSTEMS  
 2755 AVENUE SCOTT  
 VALENCIA, CA 91355  
 661.257.9282  
 FAX 661.295.5638  
 BEVERLY HILLS 310.659.1718  
 E-MAIL: [tlifts@auton.com](mailto:tlifts@auton.com)  
 INTERNET: <http://www.auton.com>

- Since 1955
  - Inventor - Rack & Pinion TV Lift
  - World's Oldest & Largest Manufacturer of TV Lifts
  - Ready for Quick, Easy Installation
  - Welded Steel Construction for Maximum Strength
  - Smooth Rack & Pinion Operation
  - Standard Built-In RF circuit with remote
- NOTE: Lift can not be less than 40" Wide  
 Lift can not be more than 64" wide

EFFECTIVE: June 01, 2005

ALL MEASUREMENTS IN INCHES

Model	A	B	C	D	E	F	G	Travel	Max Load
1000.5-P SMART	40	30	9	37.25	38.5	5	7	25	150 Lbs
1001-P SMART	46	33	9	43.25	44.5	5	7	28	200 Lbs
1002-P SMART	54	35	9	51.25	52.5	5	7	30	200 Lbs
1003-P SMART	64	40	9	61.25	62.5	5	7	35	250 Lbs
CUSTOM									