

# AUTON MOTORIZED LCD DISPLAY LIFT

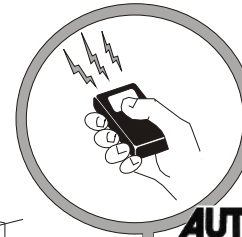
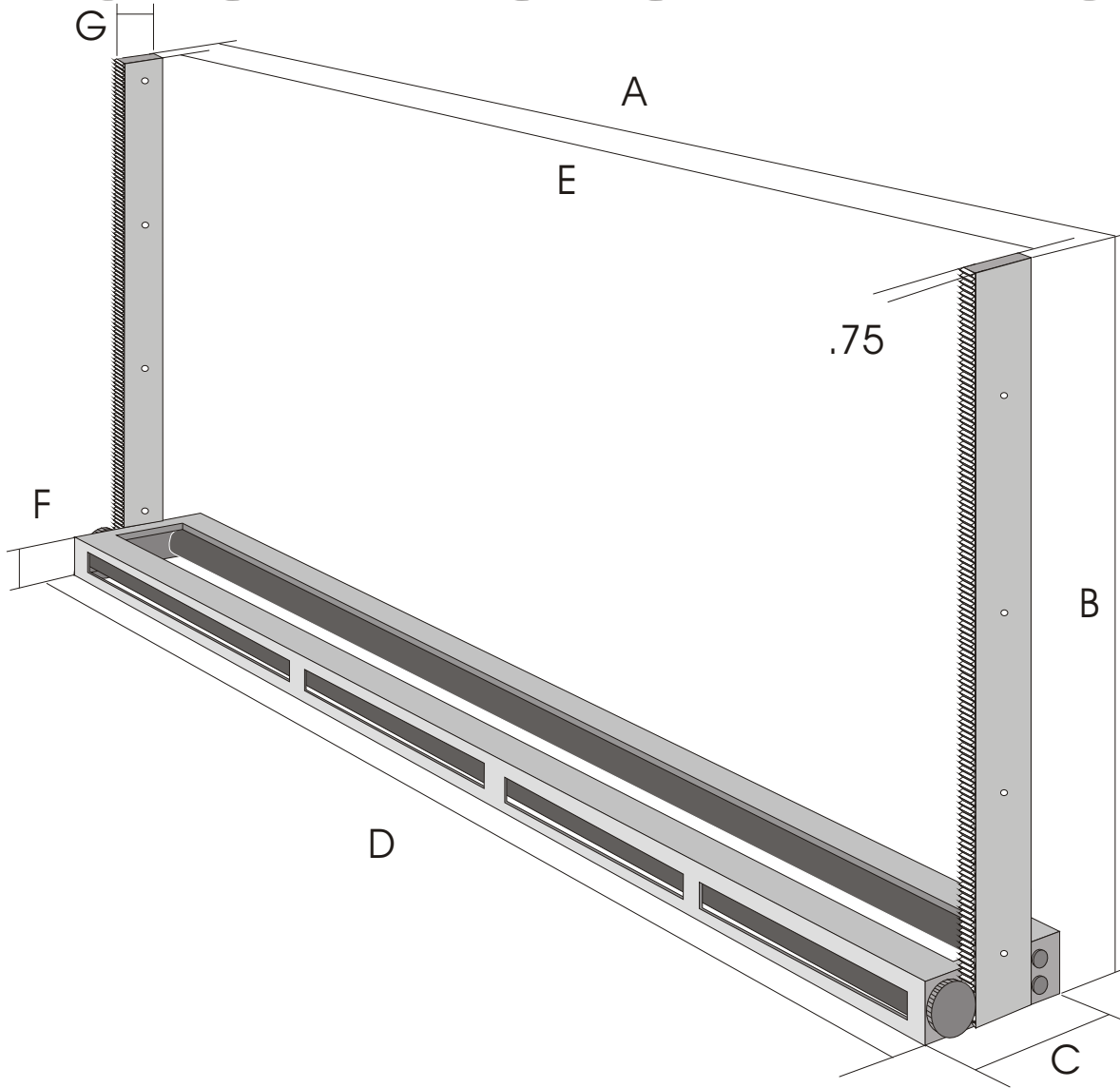

## AUTON POP UP TV LIFTS

AUTON MOTORIZED SYSTEMS  
 27555 AVENUE SCOTT  
 VALENCIA, CA 91355  
 661.257.9282  
 FAX 661.295.5638  
 BEVERLY HILLS 310.659.1718  
 E-MAIL: tvlifts@auton.com  
 INTERNET <http://www.auton.com>

- Since 1955
- Inventor - Rack & Pinion TV Lift
- World's Oldest & Largest Manufacturer of TV Lifts
- Ready for Quick, Easy Installation
- Welded Steel Construction for Maximum Strength
- Smooth Rack & Pinion Operation
- Optional Controllers for this Model:
  - Radio Remote (S4P-RF)
  - Infrared Remote (S4P-IR)
  - Low Voltage/Dry Contact Control (LV56)
  - Momentary Rocker Switch (RS-3MO)
  - Maintain Rocker Switch (RS-3MA)
  - Current Sensor (S4P-CS)

EFFECTIVE: June 1, 2005

ALL MEASUREMENTS IN INCHES

Model	A	B	C	D	E	F	G	Travel	Max Load
1000-D	20	20	5	17.25	18.5	4.5	3	15	40
CUSTOM									